

SPX10 DuCoNite®



FEATURES

- ✓ Can run dry indefinitely without damage (no product in line)
- ✓ Highly suitable for handling abrasive, shear sensitive, viscous, high density products and corrosive liquids
- ✓ Smooth liquid passage without valves, dead corners or glands
- ✓ 100% positive flow (no slip)
- ✓ Accurate (+/- 1%) dosing (metering) capabilities
- ✓ Product pumped does not contact mechanical parts or seals
- ✓ Possibility of choice of high or low pressure rotor greatly enhances hose life
- ✓ Only wearing part is the hose
- ✓ Easy maintenance low cost, short downtime. Replacement of hose without dismantling pump
- ✓ Heavy duty bearings, greased for life
- ✓ Easily and completely cleanable
- ✓ Reversible rotation
- ✓ Suitable for high viscosities and densities
- ✓ No metal to metal contact
- ✓ 100% positive flow (no slip)
- ✓ Low noise level
- ✓ Safe use for explosive environments
- ✓ Designed to pump liquids containing particles (abrasion is no restriction)
- ✓ Permanent lubrication and cooling of pump element with specially compounded food grade lubricant
- ✓ Self priming to 95% vacuum (5 kPa.a)
- ✓ Two year comprehensive warranty
- ✓ Patented direct coupled design with rotor supporting integrated into the pump head and unique buffer zone to provide protective barrier between pump head and drive arrangement
- ✓ Ultra compact footprint with flanged helical gearing; no coupling or drive alignment required

SPX Hose Pumps

Improve your process performance

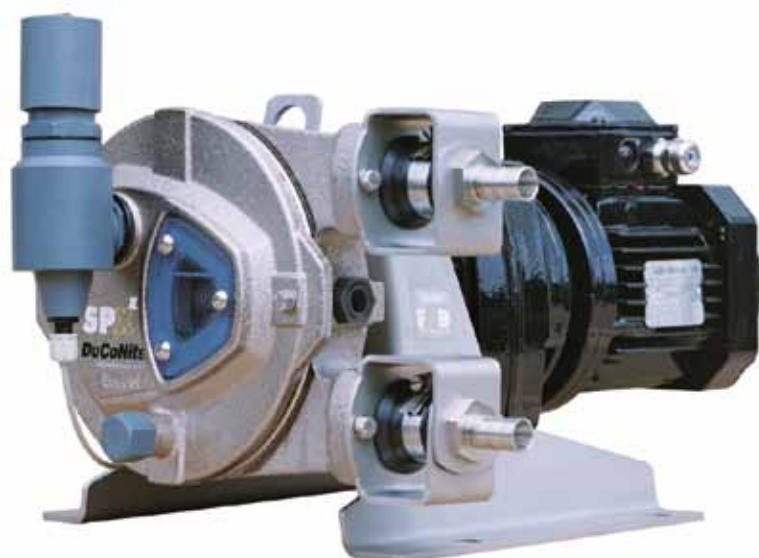

The perfect pump for the perfect application

SPX10 DuCoNite

- Maximum flow: **145 L/h**
- Capacity: **0.022 L/rev**
- Maximum discharge pressure: **750 kPa [7.5 bar]**
- Inner diameter pump element: **∅ 10 mm**
- Lubricant required: **0.25 litres**
- Minimum starting torque: **47 Nm**

Required motor power [kW]

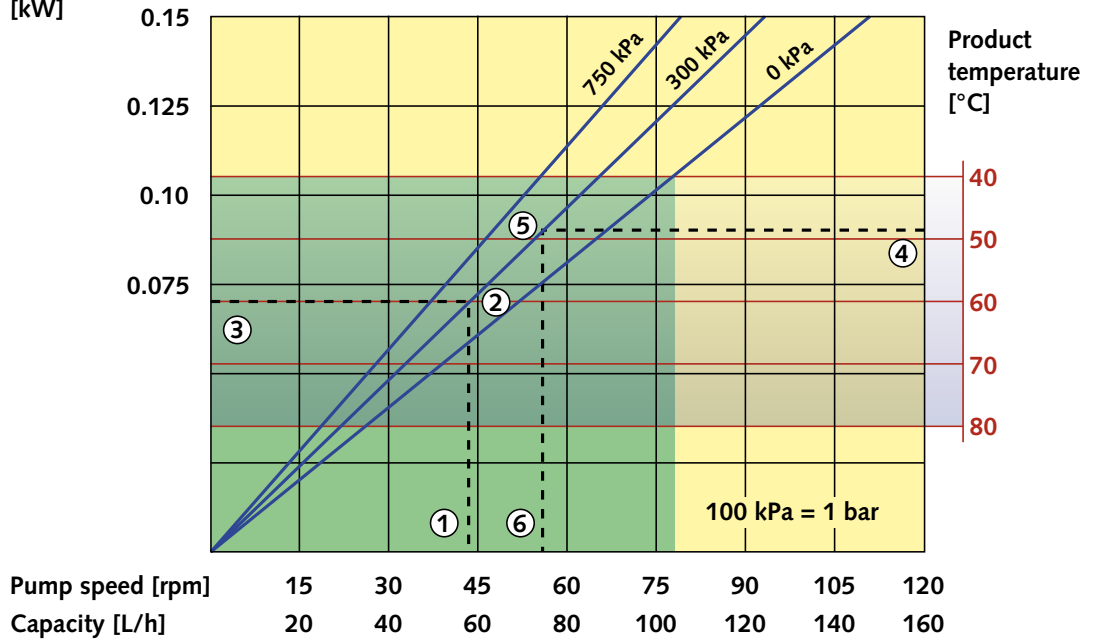

■ Continuous Duty
 ■ Intermittent Duty
 Maximum 2 hours operation followed by minimum 1 hour stop

HOW TO USE THE CURVES

1. Flow required indicates pump speed
2. Calculated discharge pressure
3. Net motor power required
4. Product temperature
5. Calculated discharge pressure
6. Maximum recommended pump speed

Note: The area of continuous operation diminishes with increased product temperatures.

For product temperatures > 40 °C, the area of continuous operation reduces to the corresponding red temperature line.

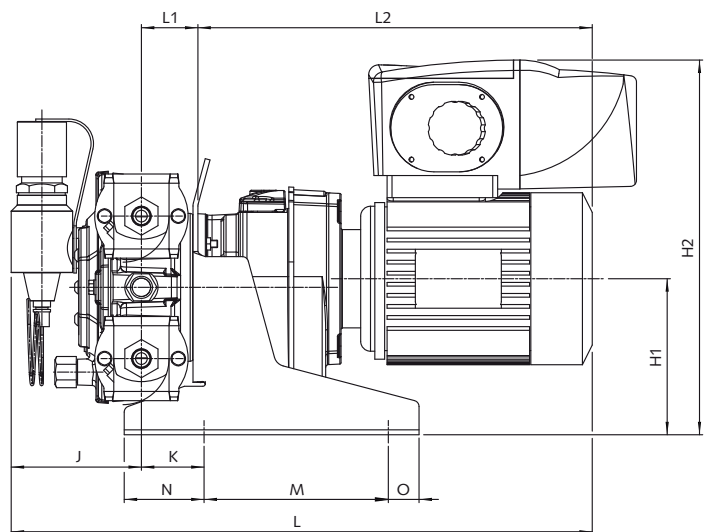
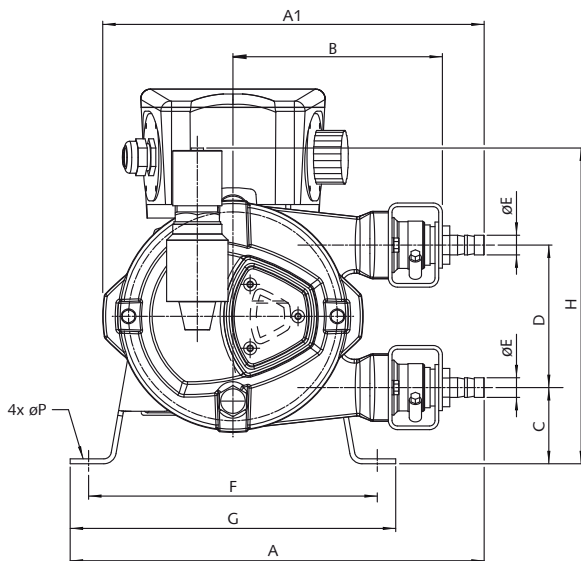

Type	A	A1	B	C	D	E	F	G	H	H1	H2 max	J	K	L max	L1	L2 max	M	N	O	P
SPX10 DuCoNite®	337	311	171	62	116	∅16	235	265	225	127	319	78	51	501	46	354	150	65	25	∅12

All dimensions in [mm]

TECHNICAL SPECIFICATIONS

Supply:	230/400 V - 3 phases - 50 Hz
Operating Speeds:	up to 82 rpm continuous; up to 110 rpm intermittent
Minimum starting torque:	47 Nm
Product Temperature Range*:	-10 °C up to 80 °C
Ambient Temperature Range**:	-20 °C up to 45 °C
Hose Lubricant Required:	0.25 litres
Flow Range:	up to 145 L/hr
Discharge Pressure:	high pressure rotor: up to 750 kPa [7.5 bar] low pressure rotor: 400 kPa [4 bar]
Suction Pressure:	9.5 metre lift to 200 kPa [2 bar]
Available Hose Materials:	EPDM
Available pump element nipple assembly:	PTFE, PVDF, AISI 316
Available flanges:	ASA AISI 316, DIN AISI 316, DIN/ANSI Titanium
Available inserts:	PP, AISI 316, Titanium, threaded nipple (BSP) AISI 316
Optional High Level Hose Leak Sensor:	NO or NC: 1A max, 250V max, 50 VA max

MATERIALS OF CONSTRUCTION

Pumphousing:	Cast-iron covered with
Rotor with Integral Shoes:	Cast-iron covered with
Bearing Hub:	Not applicable
Cover:	Cast-iron
Brackets:	AISI 316
Support Frame:	AISI 316
Fasteners:	AISI 316
Hose Clamps:	AISI 316
Coupling:	Alloy Steel
Seals:	VITON and EPDM
Pumphead Weight:	12 kg

* Please consult your Bredel representative for lower or higher temperature operation.

** Allowable ambient temperature is based on pump capabilities and may be further limited by gearbox ambient capabilities.

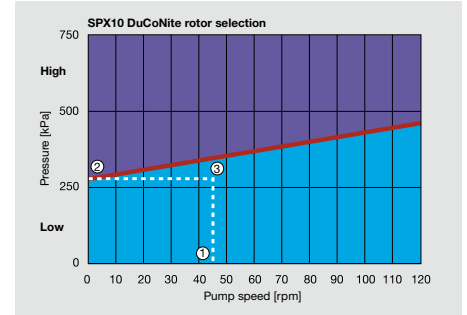

SELECTION OF ROTOR SIZE.

Determine operating point (rpm/discharge pressure).

- 1 Required pump speed;
- 2 Calculated discharge pressure;
- 3 When operating below the red line the Low pressure rotor is used. When operating above the red line the High pressure rotor is used.

REMARK

With a variable speed drive and operating in both areas, the High pressure rotor should be used.

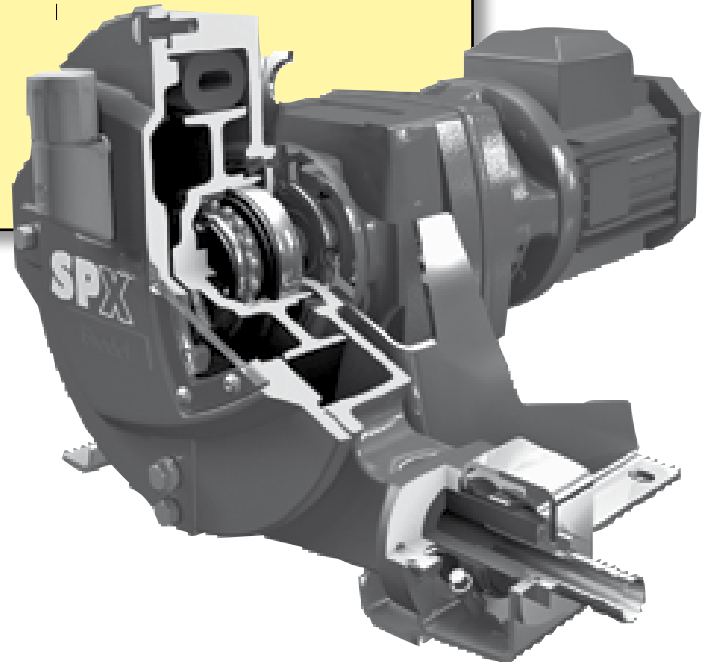
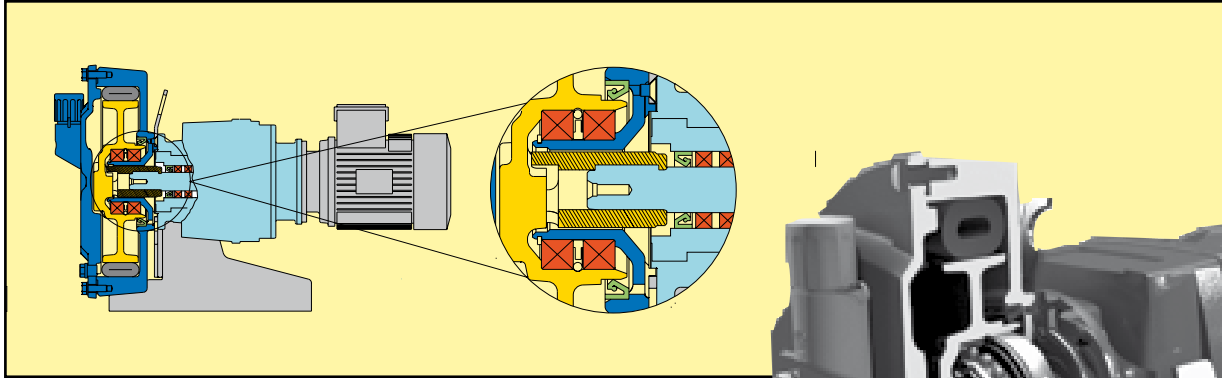

**WATSON
MARLOW**
Bredel

www.bredel.com

Sluisstraat 7 - P.O. Box 47 - NL-7490 AA Delden - The Netherlands

Tel.: +31 74 3770000 - Fax: +31 74 3761175 - Email: hosepumps@wmpg.com

Watson-Marlow... Innovation in Full Flow

The information contained in this document is believed to be correct at the time of publication, but Watson-Marlow Bredel accepts no liability for any error it contains, and reserves the right to alter specifications without prior notice. All mentioned values in this document are values under controlled circumstances at our test bed. Actual flow rates achieved may vary because of changes in temperature, viscosity, inlet and discharge pressures and/or system configuration. SPX, **DuCoNite**, Bioprene® and Bredel are registered trademarks.



NEN-EN-ISO

9001:2000